



Features

- Includes ESD protection, level-shifting, buffering and sync impedance matching
- 7 channels of ESD protection for all VGA port connector pins meeting IEC-61000-4-2 Level 4 ESD requirements ($\pm 8\text{kV}$ contact discharge)
- Very low loading capacitance from ESD protection diodes on VIDEO lines, 4pF maximum
- 5V drivers for HSYNC and VSYNC lines
- Integrated impedance matching resistors on sync lines
- Bi-directional level shifting N-channel FETs provided for DDC_CLK & DDC_DATA channels
- Backdrive protection on DDC lines
- Compact 16-lead QSOP package
- RoHS compliant (lead-free) finishing

Applications

VGA and DVI-I ports in:

- Desktop and Notebook PCs
- Graphics Cards
- Set Top Boxes

Product Description

The CM2009 connects between a video graphics controller embedded in a PC, graphics adapter card or set top box and the VGA or DVI-I port connector. The CM2009 incorporates ESD protection for all signals, level shifting for the DDC signals and buffering for the SYNC signals. ESD protection for the video, DDC and SYNC lines is implemented with low-capacitance current steering diodes. All ESD diodes are designed to safely handle the high current spikes specified by IEC-61000-4-2 Level 4 ($\pm 8\text{kV}$ contact discharge if C_{BYP} is present, $\pm 4\text{kV}$ if not). The ESD protection for the DDC signal pins are designed to prevent "back current" when the device is powered down while connected to a monitor that is powered up.

Separate positive supply rails are provided for the VIDEO, DDC and SYNC channels to facilitate interfacing with low voltage video controller ICs to provide design flexibility in multi-supply-voltage environments.

Two non-inverting drivers provide buffering for the HSYNC and VSYNC signals from the video controller IC (SYNC1, SYNC2). These buffers accept TTL input levels and convert them to CMOS output levels that swing between Ground and $V_{\text{CC_SYNC}}$, which is typically 5V. Additionally, each driver has a series termination resistor (R_T) connected to the SYNC_OUT pin, eliminating the external termination resistors typically required for the HSYNC and VSYNC lines of the video cable. There are three versions with different values of R_T to allow termination at typically 65Ω (CM2009-00) or 15Ω (CM2009-02).

The 15Ω (CM2009-02) version will typically require two external resistors which can be chosen to exactly match the characteristic impedance of the SYNC lines of the video cable.

Two N-channel MOSFETs provide the level shifting function required when the DDC controller is operated at a lower supply voltage than the monitor. The gate terminals for these MOSFETs ($V_{\text{CC_DDC}}$) should be connected to the supply rail (typically 3.3V) that supplies power to the transceivers of the DDC controller.

Simplified Electrical Schematic

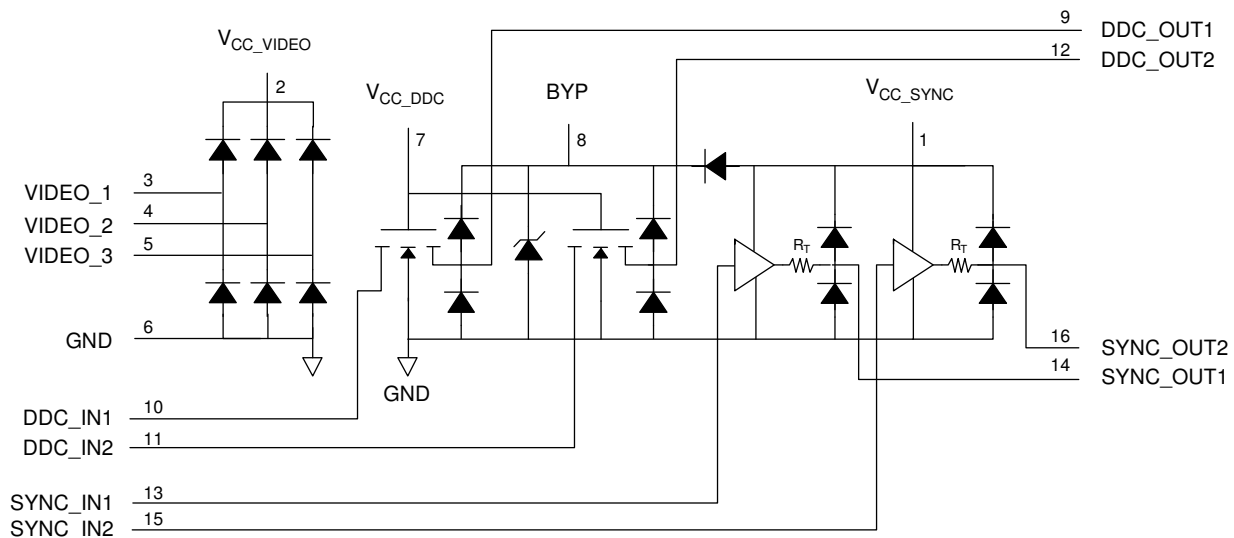

Top View

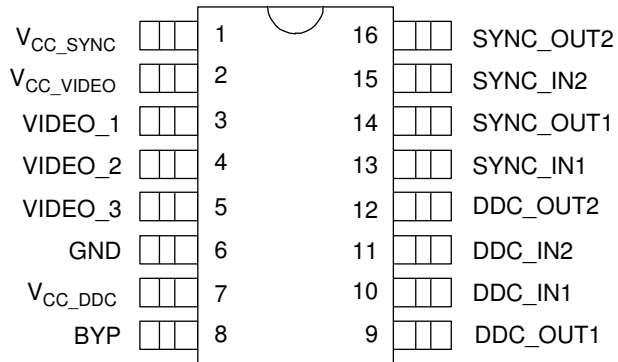

16 Pin QSOP

Note: This drawing is not to scale.

Ordering Information

PART NUMBERING INFORMATION				
R_{OUT}	Pins	Package	Ordering Part Number ¹	Part Marking
65Ω	16	QSOP	CM2009-00QR	CM2009 00QR
15Ω	16	QSOP	CM2009-02QR	CM2009 02QR

Note 1: Parts are shipped in Tape & Reel form unless otherwise specified.

Pin Description

PIN DESCRIPTIONS		
LEAD(s)	NAME	DESCRIPTION
1	V_{CC_SYNC}	This is an isolated supply input for the SYNC_1 and SYNC_2 level shifters and their associated ESD protection circuits.
2	V_{CC_VIDEO}	This is a supply pin specifically for the VIDEO_1, VIDEO_2 and VIDEO_3 ESD protection circuits.
3	VIDEO_1	Video signal ESD protection channel. This pin is typically tied one of the video lines between the VGA controller device and the video connector.
4	VIDEO_2	Video signal ESD protection channel. This pin is typically tied one of the video lines between the VGA controller device and the video connector.
5	VIDEO_3	Video signal ESD protection channel. This pin is typically tied one of the video lines between the VGA controller device and the video connector.
6	GND	Ground reference supply pin.
7	V_{CC_DDC}	This is an isolated supply input for the DDC_1 and DDC_2 level-shifting N-FET gates.
8	BYP	This input is used to connect an external 0.2uF bypass capacitor to the DDC circuits, resulting in an increased ESD withstand voltage rating ±8kV with vs. ±4kV without).
9	DDC_OUT1	DDC signal output. Connects to the video connector side of one of the sync lines.
10	DDC_IN1	DDC signal input. Connects to the VGA controller side of one of the sync lines.
11	DDC_IN2	DDC signal input. Connects to the VGA controller side of one of the sync lines.
12	DDC_OUT2	DDC signal output. Connects to the video connector side of one of the sync lines.
13	SYNC_IN1	Sync signal buffer input. Connects to the VGA controller side of one of the sync lines.
14	SYNC_OUT1	Sync signal buffer output. Connects to the video connector side of one of the sync lines.
15	SYNC_IN2	Sync signal buffer input. Connects to the VGA controller side of one of the sync lines.
16	SYNC_OUT2	Sync signal buffer output. Connects to the video connector side of one of the sync lines.

Specifications

ABSOLUTE MAXIMUM RATINGS

PARAMETER	RATING	UNITS
V_{CC_VIDEO} , V_{CC_DDC} and V_{CC_SYNC} Supply Voltage Inputs	[GND - 0.5] to +6.0	V
ESD Diode Forward Current (one diode conducting at a time)	10	mA
DC Voltage at Inputs VIDEO_1, VIDEO_2, VIDEO_3 DDC_IN1, DDC_IN2 DDC_OUT1, DDC_OUT2 SYNC_IN1, SYNC_IN2	[GND - 0.5] to [$V_{CC_VIDEO} + 0.5$] [GND - 0.5] to 6.0 [GND - 0.5] to 6.0 [GND - 0.5] to [$V_{CC_SYNC} + 0.5$]	V V V V
Operating Temperature Range	-40 to +85	°C
Storage Temperature Range	-40 to +150	°C
Package Power Rating ($T_A=25^\circ\text{C}$)	500	mW

ELECTRICAL OPERATING CHARACTERISTICS (SEE NOTE 1)

SYMBOL	PARAMETER	CONDITIONS	MIN	TYP	MAX	UNITS
I_{CC_VIDEO}	V_{CC_VIDEO} Supply Current	$V_{CC_VIDEO} = 5.0\text{V}$; VIDEO inputs at V_{CC_VIDEO} or GND			10	μA
I_{CC_DDC}	V_{CC_DDC} Supply Current	$V_{CC_DDC} = 5.0\text{V}$			10	μA
I_{CC_SYNC}	V_{CC_SYNC} Supply Current	$V_{CC_SYNC} = 5\text{V}$; SYNC inputs at GND or V_{CC_SYNC} ; SYNC outputs unloaded			50	μA
		$V_{CC_SYNC} = 5\text{V}$; SYNC inputs at 3.0V; SYNC outputs unloaded			2.0	mA
V_F	ESD Diode Forward Voltage	$I_F = 10\text{mA}$			1.0	V
V_{IH}	Logic High Input Voltage	$V_{CC_SYNC} = 5.0\text{V}$; Note 2	2.0			V
V_{IL}	Logic Low Input Voltage	$V_{CC_SYNC} = 5.0\text{V}$; Note 2			0.6	V
V_{OH}	Logic High Output Voltage	$I_{OH} = 0\text{mA}$, $V_{CC_SYNC} = 5.0\text{V}$; Note 2	4.85			V
V_{OL}	Logic Low Output Voltage	$I_{OL} = 0\text{mA}$, $V_{CC_SYNC} = 5.0\text{V}$; Note 2			0.15	V
R_{OUT}	SYNC Driver Output Resistance (CM2009-00 only)	$V_{CC_SYNC} = 5.0\text{V}$; SYNC Inputs at GND or 3.0V		65		Ω
R_{OUT}	SYNC Driver Output Resistance (CM2009-02 only)	$V_{CC_SYNC} = 5.0\text{V}$; SYNC Inputs at GND or 3.0V; Note 5		15		Ω
V_{OH-02}	Logic High Output Voltage (CM2009-02 only)	$I_{OH} = 24\text{mA}$; $V_{CC_SYNC} = 5.0\text{V}$; Note 2	2.0			V
V_{OL-02}	Logic Low Output Voltage (CM2009-02 only)	$I_{OL} = 24\text{mA}$; $V_{CC_SYNC} = 5.0\text{V}$; Note 2			0.8	V

CM2009

SYMBOL	PARAMETER	CONDITIONS	MIN	TYP	MAX	UNITS
I_{IN}	Input Current VIDEO Inputs	$V_{CC_VIDEO} = 5.0V; V_{IN} = V_{CC_VIDEO}$ or GND			± 1	μA
	SYNC_IN1, SYNC_IN2 Inputs	$V_{CC_SYNC} = 5.0V; V_{IN} = V_{CC_SYNC}$ or GND			± 1	μA
I_{OFF}	Level Shifting N-MOSFET "OFF" State Leakage Current	$(V_{CC_DDC} - V_{DDC_IN}) \leq 0.4V; V_{DDC_OUT} = V_{CC_DDC}$			10	μA
		$(V_{CC_DDC} - V_{DDC_OUT}) \leq 0.4V; V_{DDC_IN} = V_{CC_DDC}$			10	μA
V_{ON}	Voltage Drop Across Level-shifting N-MOSFET when "ON"	$V_{CC_DDC} = 2.5V; V_S = GND; I_{DS} = 3mA;$			0.18	V
C_{IN_VID}	VIDEO Input Capacitance	$V_{CC_VIDEO} = 5.0V; V_{IN} = 2.5V; f = 1MHz; \text{Note 4}$			4	pF
		$V_{CC_VIDEO} = 2.5V; V_{IN} = 1.25V; f = 1MHz; \text{Note 4}$			4.5	pF
t_{PLH}	SYNC Driver L => H Propagation Delay	$C_L = 50pF; V_{CC} = 5.0V; \text{Input } t_r \text{ and } t_f \leq 5ns$			12	ns
t_{PHL}	SYNC Driver H => L Propagation Delay	$C_L = 50pF; V_{CC} = 5.0V; \text{Input } t_r \text{ and } t_f \leq 5ns$			12	ns
t_r, t_f	SYNC Driver Output Rise & Fall Times	$C_L = 50pF; V_{CC} = 5.0V; \text{Input } t_r \text{ and } t_f \leq 5ns$		4		ns
V_{ESD}	ESD Withstand Voltage	$V_{CC_VIDEO} = V_{CC_SYNC} = 5V; \text{Notes 3, 4 \& 5}$	± 8			kV

Note 1: All parameters specified over standard operating conditions unless otherwise noted.

Note 2: These parameters apply only to the SYNC drivers. Note that $R_{OUT} = R_T + R_{BUFFER}$.

Note 3: Per the IEC-61000-4-2 International ESD Standard, Level 4 contact discharge method. BYP, V_{CC_VIDEO} and V_{CC_SYNC} must be bypassed to GND via a low impedance ground plane with a 0.2 μF , low inductance, chip ceramic capacitor at each supply pin. ESD pulse is applied between the applicable pins and GND. ESD pulses can be positive or negative with respect to GND. Applicable pins are: VIDEO_1, VIDEO_2, VIDEO_3, SYNC_OUT1, SYNC_OUT2, DDC_OUT1 and DDC_OUT2. All other pins are ESD protected to the industry standard 2kV Human Body Model (MIL-STD-883, Method 3015). The bypass capacitor at the BYP pin may optionally be omitted, in which case the max. ESD withstand voltage for the DDC_OUT1 and DDC_OUT2 pins are reduced to $\pm 4kV$.

Note 4: The SYNC_OUT pins on the CM2009-02 are guaranteed for 2kV HBM ESD protection.

Application Information

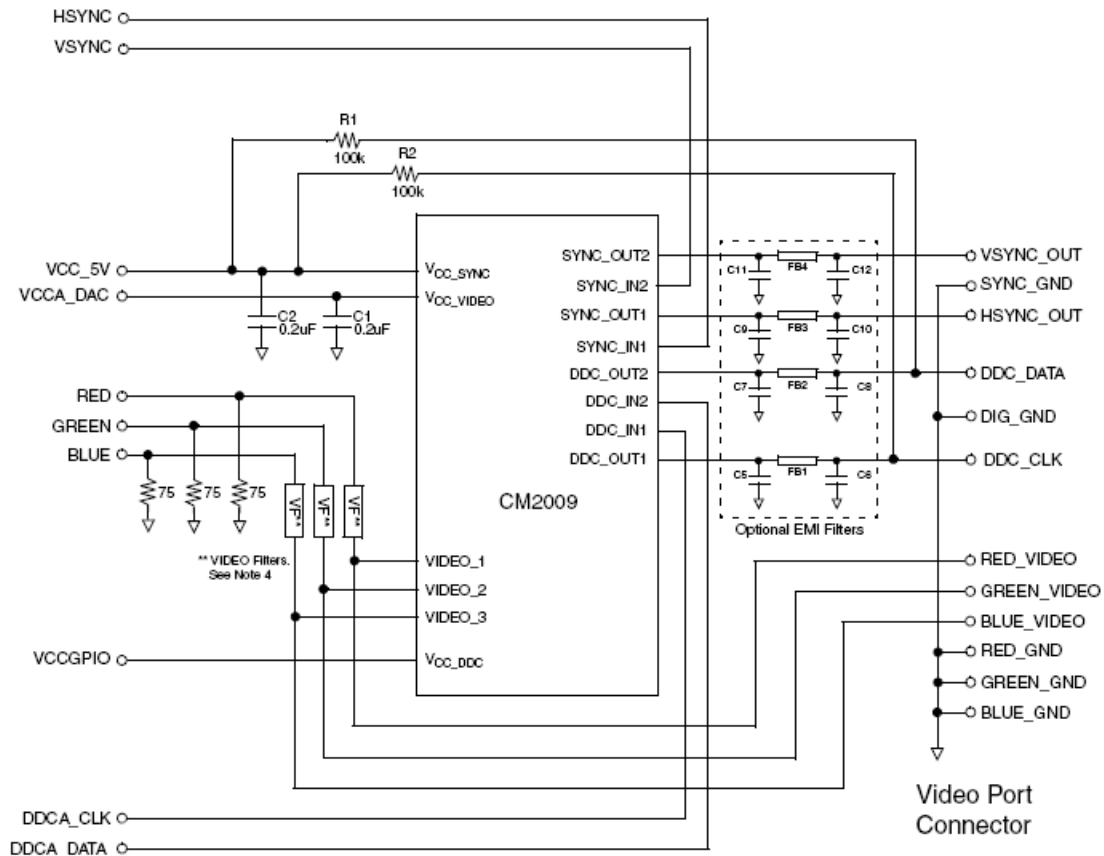

Figure 1. Typical Application Connection Diagram

NOTES

- 1 The CM2009 should be placed as close to the VGA or DVI-I connector as possible.
- 2 The ESD protection channels VIDEO_1, VIDEO_2, VIDEO_3 may be used interchangeably between the R, G, B signals.
- 3 If differential video signal routing is used, the RED, BLUE, and GREEN signal lines should be terminated with external 37.5 resistors.
- 4 "VF" are external video filters for the RGB signals.
- 5 Supply bypass capacitors C1 and C2 must be placed immediately adjacent to the corresponding Vcc pins. Connections to the Vcc pins and ground plane must be made with minimal length copper traces (preferably less than 5mm) for best ESD protection.
- 6 The bypass capacitor for the BYP pin has been omitted in this diagram. This results in a reduction in the maximum ESD withstand voltage at the DDC_OUT pins from $\pm 8\text{kV}$ to $\pm 4\text{kV}$. If 8kV ESD protection is required, a 0.2 μF ceramic bypass capacitor should be connected between BYP and ground.
- 7 The SYNC buffers may be used interchangeably between HSYNC and VSYNC.
- 8 The EMI filters at the SYNC_OUT and DDC_OUT pins (C5 to C12, and Ferrite Beads FB1 to FB4) are for reference only. The component values and filter configuration may be changed to suit the application.
- 9 The DDC level shifters DDC_IN, DDC_OUT, may be used interchangeably between DDCA_CLK and DDCA_DATA.
- 10 R1, R2 are optional. They may be used, if required, to pull the DDC_CLK and DDC_DATA lines to VCC_5V when no monitor is connected to the VGA connector. If used, it should be noted that "back current" may flow between the DDC pins and VCC_5V via these resistors when VCC_5V is powered down.
- 11 For optimal ESD performance with the CM2009-02, an additional clamp device (such as the CMD PACDN042) should be placed on HSYNC/VSYNC lines between the external matching resistor and the VGA connector.

Mechanical Details

QSOP Mechanical Specifications

CM2009 devices are packaged in 16-pin QSOP packages. Dimensions are presented below.

PACKAGE DIMENSIONS				
Package	QSOP (JEDEC name is SSOP)			
Pins	16			
Dimensions	Millimeters		Inches	
	Min	Max	Min	Max
A	1.35	1.75	0.053	0.069
A1	0.10	0.25	0.004	0.010
B	0.20	0.30	0.008	0.012
C	0.18	0.25	0.007	0.010
D	4.80	5.00	0.189	0.197
E	3.81	3.98	0.150	0.157
e	0.64 BSC		0.025 BSC	
H	5.79	6.19	0.228	0.244
L	0.40	1.27	0.016	0.050
# per tube	100 pcs*			
# per tape and reel	2500 pcs			
Controlling dimension: inches				

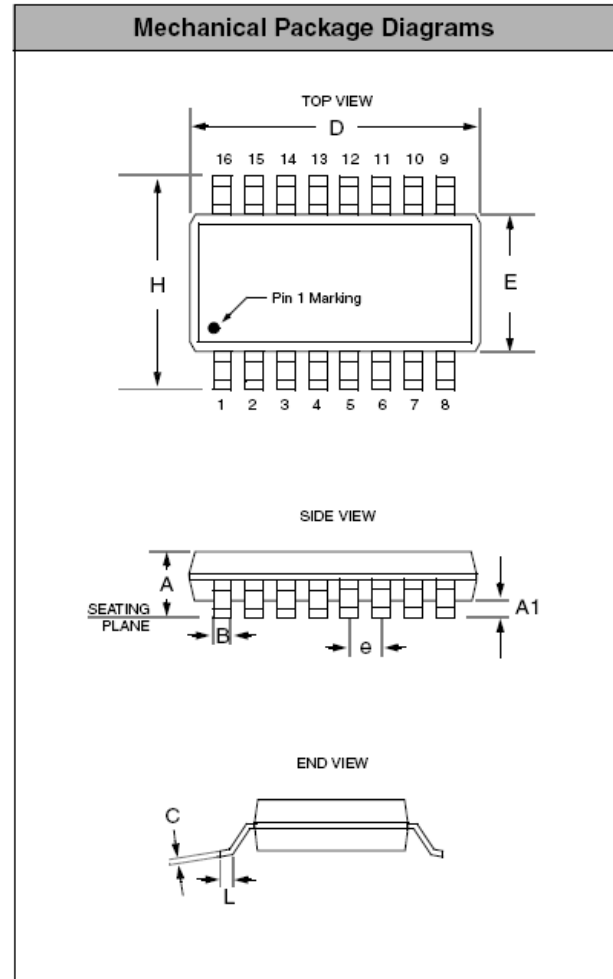

Package Dimensions for QSOP-16

* This is an approximate number which may vary.

ON Semiconductor and  are registered trademarks of Semiconductor Components Industries, LLC (SCILLC). SCILLC reserves the right to make changes without further notice to any products herein. SCILLC makes no warranty, representation or guarantee regarding the suitability of its products for any particular purpose, nor does SCILLC assume any liability arising out of the application or use of any product or circuit, and specifically disclaims any and all liability, including without limitation special, consequential or incidental damages. "Typical" parameters which may be provided in SCILLC data sheets and/or specifications can and do vary in different applications and actual performance may vary over time. All operating parameters, including "Typicals" must be validated for each customer application by customer's technical experts. SCILLC does not convey any license under its patent rights nor the rights of others. SCILLC products are not designed, intended, or authorized for use as components in systems intended for surgical implant into the body, or other applications intended to support or sustain life, or for any other application in which the failure of the SCILLC product could create a situation where personal injury or death may occur. Should Buyer purchase or use SCILLC products for any such unintended or unauthorized application, Buyer shall indemnify and hold SCILLC and its officers, employees, subsidiaries, affiliates, and distributors harmless against all claims, costs, damages, and expenses, and reasonable attorney fees arising out of, directly or indirectly, any claim of personal injury or death associated with such unintended or unauthorized use, even if such claim alleges that SCILLC was negligent regarding the design or manufacture of the part. SCILLC is an Equal Opportunity/Affirmative Action Employer. This literature is subject to all applicable copyright laws and is not for resale in any manner.

PUBLICATION ORDERING INFORMATION

LITERATURE FULFILLMENT:

Literature Distribution Center for ON Semiconductor
P.O. Box 5163, Denver, Colorado 80217 USA
Phone: 303-675-2175 or 800-344-3860 Toll Free USA/Canada
Fax: 303-675-2176 or 800-344-3867 Toll Free USA/Canada
Email: orderlit@onsemi.com

N. American Technical Support: 800-282-9855
Toll Free USA/Canada
Europe, Middle East and Africa Technical Support:
Phone: 421 33 790 2910
Japan Customer Focus Center
Phone: 81-3-5773-3850

ON Semiconductor website: www.onsemi.com

Order Literature: <http://www.onsemi.com/orderlit>

For additional information, please contact your local Sales Representative